

Fine Bubble Membrane Disc Diffuser

DFA fine pore flexible membrane diffusers are constructed with premium quality EPDM membranes engineered for superior product life, operational flexibility and maximum oxygen transfer efficiency. The units are ideally suited for continuous or on/off applications and require minimal maintenance for long-term performance.

Feature & Benefits

- Precision die cut openings for high oxygen transfer, uniform air release, and low operating pressure
- Advanced technology premium quality membranes of EPDM or special polymer blends
- Economical capital cost and ease of installation
- Triple check valve design prevents entry of liquid/solids into piping. Ideal for ON/OFF applications
- Glass fiber reinforced polypropylene construction for maximum chemical, temperature, and UV resistance
- Wide thermal capability range
- Rugged heavy duty construction
- Low maintenance, resistant to fouling and plugging
- Mounts on any pipe material (PVC, ABS, CPVC, SS, etc.)
- Available in 7 inch, 9 inch & 11 inch diameter

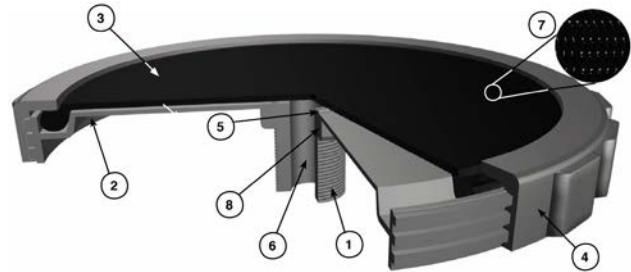

- ① Threaded 3/4 inch male NPT connector
- ② Glass-filled polypropylene diffuser base
- ③ Premium quality membrane EPDM
- ④ Glass filled polypropylene retainer ring
- ⑤ Check valve feature
- ⑥ Air inlet orifice assembly
- ⑦ Die cut perforations
- ⑧ Hex headed shank



Shown with optional Universal Diffuser Mount™ (UDM)

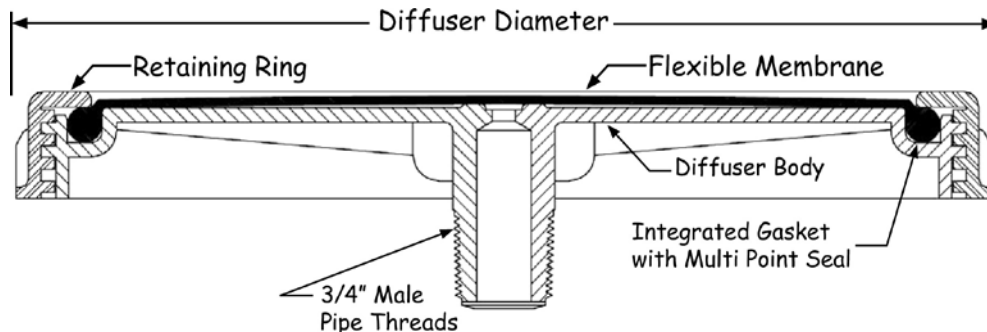

Model	Nominal Disc Size	Design Airflow		Peak Airflow		Diffuser Diameter		Active Surface Area		Dry Weight	
		scfm	sm ³ /hr	scfm	sm ³ /hr	in	mm	ft ²	m ²	lbs	kg
DFA7	7"	0.5 - 2.5	0.9 - 4.3	3.0	3.0	9.3	235	0.3	0.027	1.2	0.5
DFA9	9"	0.5 - 4.0	0.9 - 6.8	6.0	6.0	10.8	275	0.4	0.037	1.5	0.6
DFA11	11"	1.0 - 8.0	1.7 - 13.6	9.4	15	13.3	336	0.6	0.058	1.9	0.9
UDM	Universal Diffuser Mount™ for membrane disc diffuser, 3/4" FPT										

Flexible Membrane Performance Curves

9" Disc Diffuser General Oxygen Transfer Efficiency (OTE) Curves

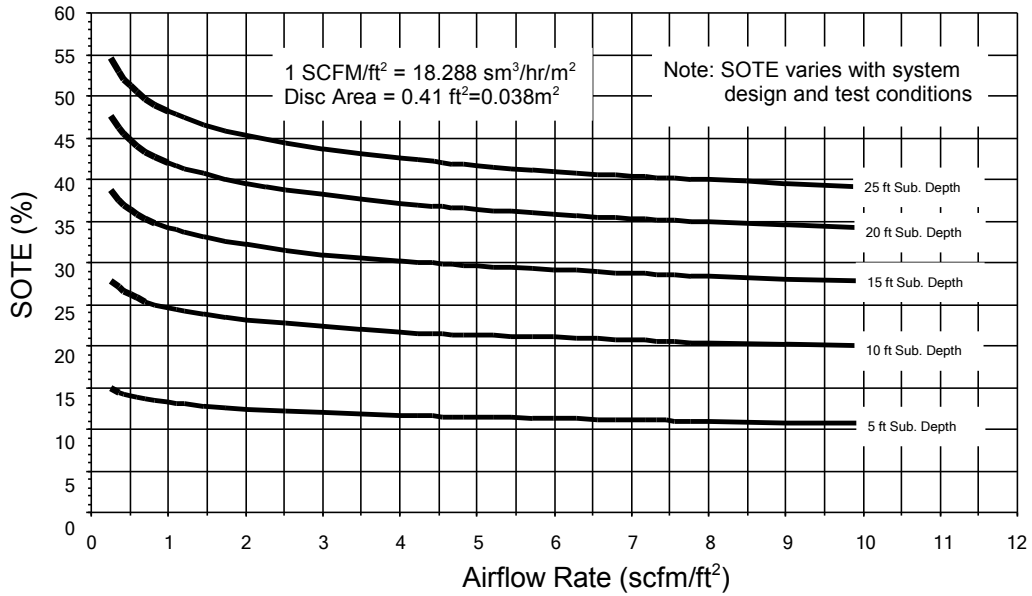

Disc Diffuser Operating Pressure

